

ASSEMBLY INSTRUCTIONS

BUDGET W.B.C. FLOOR

Included: 5 x Floorboards, 2 x Joists, 2 x Wedges, 2 x Stays, 4 x Legs, Glue, 14 x 1" Nails, 38 x 1½" Nails, 2 x 2" Nails, 8 x Screws

Tools needed: Hammer, Punch/Rampin, Set Square, Drill, Electric Screwdriver, Tape Measure, Pencil

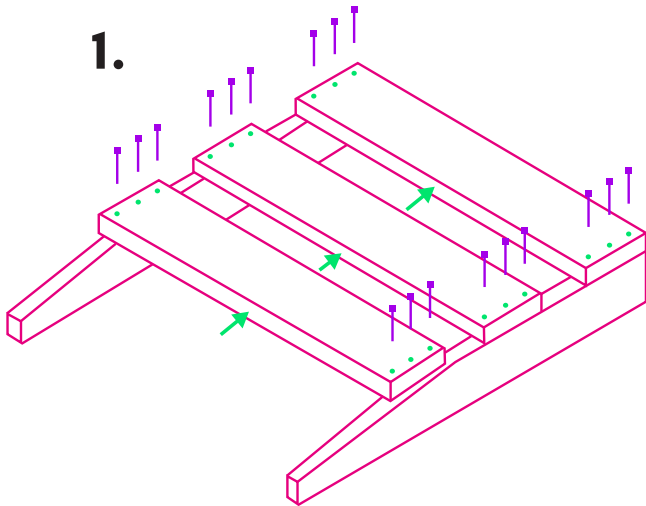

1A. For this first step you will need 18 x 1½" nails, the 2 joists and the 3 smaller floorboards.

1B. Start by placing the joists on a flat surface, as pictured, and apply glue along the top of the joist. Starting at the higher end, and place on the first floorboard. Nail in your first nail on each side and make sure everything is square before continuing. Once you are sure it is square, carry on nailing so you have a total of 3 nails in each side of your first floorboard.

1C. Move onto the next floorboard, making sure you apply glue to the joist **and** the floorboard you have just attached that this one will butt up to. Nail in 3 nails on each end of the floorboard. Repeat this one more time for the third floorboard.

2A. This next step requires the 2 remaining floorboards. You will also need another 8 x 1½" nails and 4 x 1" nails.

2B. Starting with the narrower floorboard, one edge will be beveled, this beveled edge will butt up to the last board you attached to the joists. Glue and nail in place as with the previous 3 boards.

2C. The last board you are left with will be wider than the others. Make sure you leave equal over hang either side and nail as shown in diagram. 1 x 1½" nail either side at the top, and then 2 x 1" nails to attached the board to the end of the joist underneath.

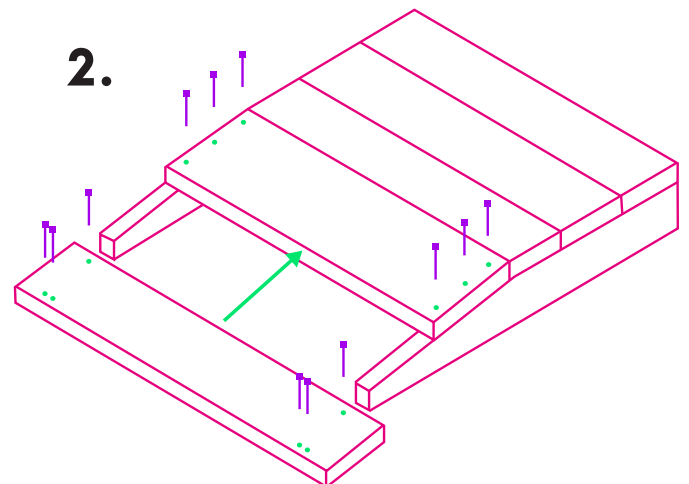

E.H. THORNE (Beehives) Ltd.

Beehive Business Park, Rand, Nr. Wragby, Lincolnshire, LN8 5NJ

www.thorne.co.uk

01673 858555

sales@thorne.co.uk

THORNE

BUDGET W.B.C. FLOOR *continued...*

3.

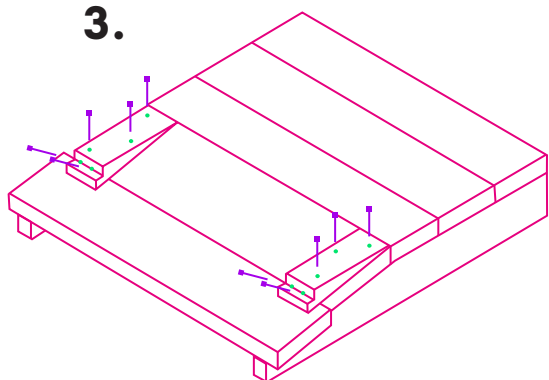

3A. You will need the 2 wedges, 10 x 1" nails and a rampin or nail punch also.

3B. Line up the wedges as shown in the diagram making sure they are the right way round and flush with the joint between the third and fourth board. Glue, then nail 3 nails in the top of each wedge, making sure not to hit nails you have already inserted, and that the nails do not protrude on the underneath.

3C. Then nail 2 nails into each the rebates as show in the diagram. This is easily done with a rampin, or part nail in with a hammer and finish with a punch.

4A. For this step you will need the 2 stays, 4 x 1½" nails and 2 x 2" nails.

4B. Measure from the back of the floor along the joist 18" (457mm) and mark on both joists. Line up the longer, rectangular stay with these marks and glue and nail into place with 2 x 1½" on each, positioned so overhang lines up with wider floorboard below.

4C. Glue and nail the shorter, square stay at the back, in line with the end of the joists, 1 x 2" nail in each end.

4.

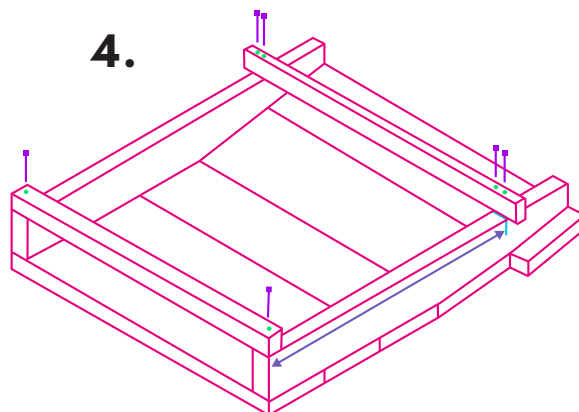

5A. This last step requires 4 x legs, 8 x 1½" nails and 8 x screws.

5B. Now you have your stays in place, each leg should slot into the corners. Use 2 screws to attached each leg, it might be easier to pre-drill the holes in the joist.

5C. Once the legs are screwed in place, nails 2 x 1½" nails through the stays and into the legs as show in the diagram.

5.

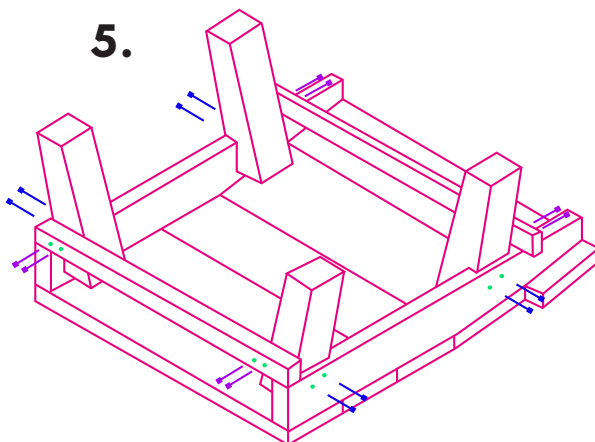

E.H. THORNE (Beehives) Ltd.

Beehive Business Park, Rand, Nr. Wragby, Lincolnshire, LN8 5NJ

www.thorne.co.uk

01673 858555

sales@thorne.co.uk

THORNE